

NOXON

# FREESBY



MACCHINE A TAVOLA ROTANTE  
PER L'AVVOLGIMENTO  
CON FILM ESTENSIBILE

TURNTABLE STRETCH  
WRAPPING MACHINES

[www.noxon.it](http://www.noxon.it)  
[www.presa.com](http://www.presa.com)

 **presa**  
ALONG YOUR LINES

## CARATTERISTICHE TECNICHE/ TECHNICAL FEATURES

MACCHINA/MACHINE	FREESBY 202	FREESBY T202	FREESBY 210	FREESBY T210	FREESBY 212	FREESBY T212	FREESBY 214	FREESBY T214
Altezza albero mm / Useful mast height mm	2200	2200	2200	2200	2200	2200	2200	2200
Diametro piatto mm / Turntable diameter mm	1650	1650	1650	1650	1650	1650	1650	1650
Portata piatto kg / Turntable capacity kg	2000	1500	2000	1500	2000	1500	2000	1500
Velocità rotazione tavola (RPM) / Table rotation speed (RPM)	5÷12	5÷12	5÷12	5÷12	5÷12	5÷12	5÷12	5÷12
Velocità salita / discesa carrello / Carriage lifting / lowering speed m/min	1,4-4	1,4-4	1,4-4	1,4-4	1,4-4	1,4-4	1,4-4	1,4-4
Tiro film / Stretch film	manuale manual		regolabile da pannello/ adjustable from control pannel					
Prestiro / Pre-stretch	NO				250% fisso/ fixed		150% - 400% variabile/ variable	
Alimentazione VAC / Power supply VAC	230 V (±20%) 1 PH 50/60 Hz							
Potenza installata kW / Installed power kW	1,5	1,5	1,5	1,5	1,9	1,9	2,3	2,3
Arresto in fase / Phase stopping point	STD	STD	STD	STD	STD	STD	STD	STD
Avvio progressivo / Soft start	STD	STD	STD	STD	STD	STD	STD	STD
Ritardo fotocellula / altimetro / Photocell delay / altimeter	STD	STD	STD	STD	STD	STD	STD	STD
Fotocellula lettura altezza carico / Load height sensing by photocell	STD	STD	STD	STD	STD	STD	STD	STD
Inforcabilità anteriore e posteriore / Front and rear forklifting	STD	posteriore/ rear	STD	posteriore/ rear	STD	posteriore/ rear	STD	posteriore/ rear

### LAYOUT FREESBY

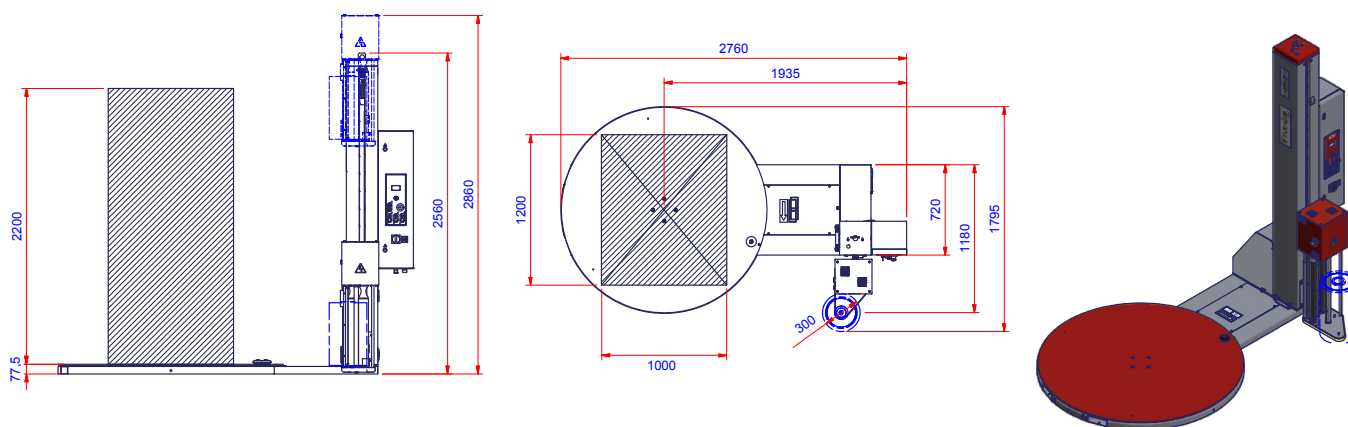

I CONTENUTI DI QUESTO CATALOGO SONO STATI VERIFICATI AL MOMENTO DELLA STAMPA. NOXON SI RISERVA IL DIRITTO DI MODIFICARE IN OGNI MOMENTO LE CARATTERISTICHE TECNICHE DEI PRODOTTI E DEGLI ACCESSORI ILLUSTRATI NEL PRESENTE DOCUMENTO. / THE CONTENTS OF THESE CATALOGS HAVE BEEN VERIFIED BEFORE THE PRESS. NOXON RESERVES THE RIGHT TO MODIFY IN EVERY MOMENT THE TECHNICAL CHARACTERISTICS OF THE PRODUCTS AND ACCESSORIES ILLUSTRATED IN THE PRESENT DOCUMENT.

**NOXON**

**PRESA NV**, Brusselssteenweg 558, 3090 Overijse, Belgium  
Tel. 0032-2-657.02.22. Mail: info@presa.com Web: www.presa.com

**presa**  
ALONG YOUR LINES